

HAGAB®

BASIC 2

Non-return damper

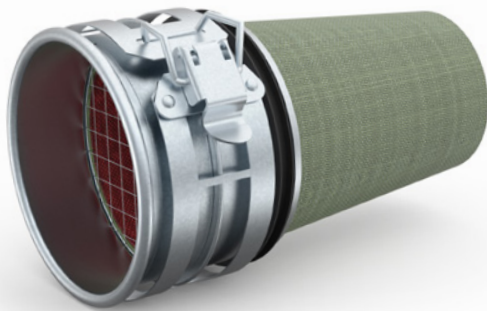

BASIC 2 non-return dampers prevent fire gases from spreading in buildings with FTX systems and operating fans. Suitable for apartments, hotels and elderly housing. Type approved.

NON-RETURN DAMPER BASIC

Basic 2 is installed in the distribution box to prevent the spread of fire gas via the supply air system.

The exhaust air system is dimensioned for the evacuation of fire gas. Both the supply air and exhaust air fans must be in operation throughout the course of the fire. The product is

self-acting and contains no moving mechanical parts. The distribution box can be positioned with any exhaust direction, for example in attics, cellar ceilings or against walls, see fig. 1.

In all cases, BASIC 2 must be accessible for inspection.

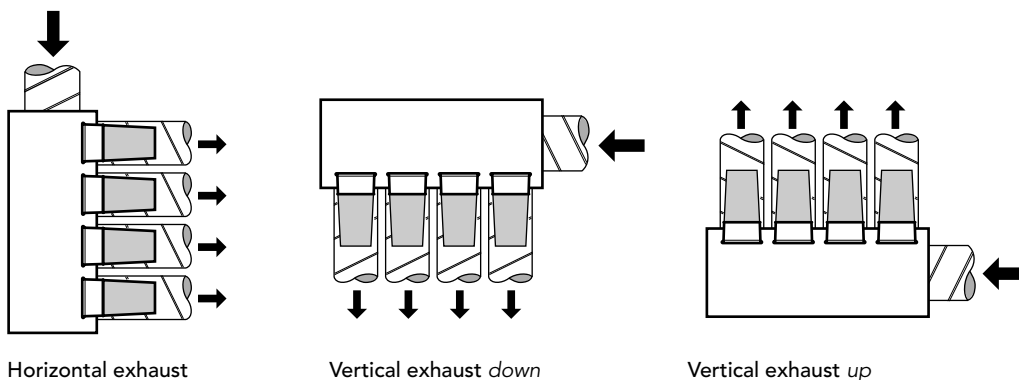

fig 1.



HAGAB®

BASIC 2

Non-return damper

INSTALLATION

General

- Terminate the end of the duct at least 20 mm above floor level. (A)
- Basic extends 63 mm beyond the end of the duct. (B)

To achieve the best possible air distribution when Basic is installed in a distribution box, we recommend the following:

- Avoid speeds in the inlet duct which exceed the speed in any of the outlet ducts.
- Ensure the distribution box has the greatest possible volume.
- Ensure there is a gap between the bottom edge of the inlet duct and the top edge of Basic. (C)
- Straight sections after Basic should exceed four times the duct diameter in order to minimize detrimental connection effects. (D)

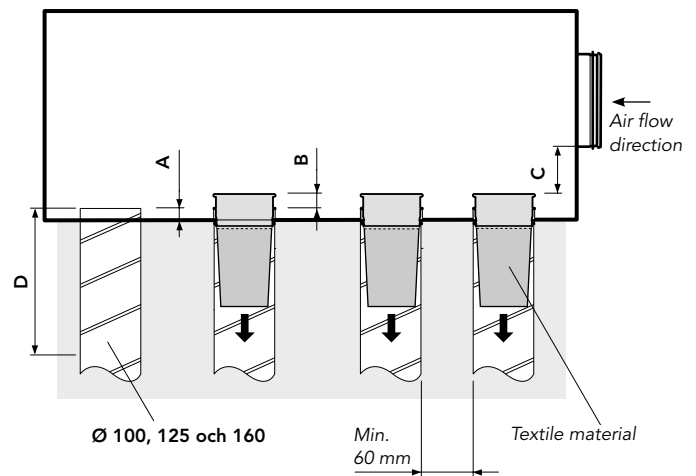

INSTALLATION PROCEDURE

- Pull the supplied mounting strap over the end of the duct.
- Press Basic into the duct with the textile material stretched out.
- Tighten the mounting strap over the joint between the end of the duct and Basic.

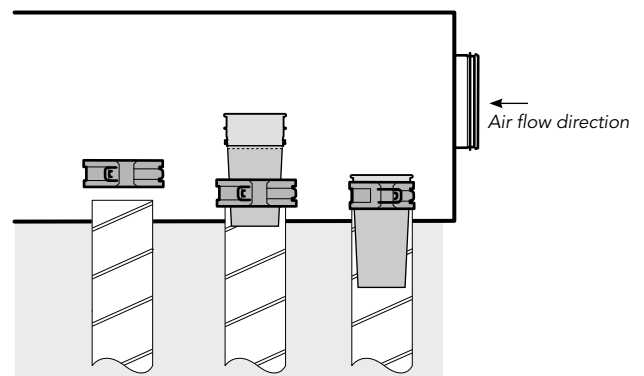

HAGAB®

BASIC 2

Non-return damper

INSPECTION AND CLEANING

Perform a random schematic inspection every three years.

Also perform an inspection and any cleaning:

- When converting the ventilation system.
- When cleaning the duct system.

PERFORMING AN INSPECTION

- Check that the material in the inner and outer cloth bag is intact.
- Vacuum clean the bags if necessary.
- Check and clean the protective mesh if necessary.
- Check the closing function by holding Basic 2 with the cloth cone turned towards the air flow direction in the distribution box inlet duct.

DISMANTLING AND RE-ASSEMBLY

- Open the distribution box.
- Unfasten the snap lock.
- Remove BASIC 2.
- Check and clean if necessary.
- Re-assemble and ensure that the textile material is stretched out.
- Close the cover of the distribution box so that it is sealed tightly.

